

SUBMITTAL DATA SHEET

NI_AP_IN_0034.docx
Rev. -0 of 09/06/2022



NIRON CLIMA ALLPRO FITTINGS 45° PREINSULATED EXTENDED BEND

ITEM: 27NC45AP_11MML
SIZE RANGE: 1" (32 mm) ÷ 12" (315 mm)
SDR: 9, 11
FUSION RANGE: For Butt Fusion – SDR 9, 11 and up
For Electrofusion – SDR 9, 11 and up
MATERIAL: PP-RCT + Fiber glass + PUF + PPR jacket
COLOR: Grey (carrier pipe) + Grey with white outer layer (jacket pipe)
WELDING SYSTEM: 

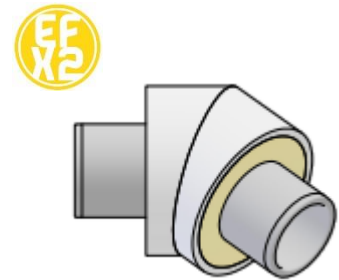

INSTALLATION INSTRUCTIONS:

In accordance with DVS 2207, ASTM D2657 and NUPI AllPro Niron Catalog/Price Sheet

LISTINGS:

uNSF-14; ICC-ES; IAPMO

STANDARDS:

ANS/NSF 14; ASTM F2389; CSA B137.11; CAN/ULC S102.2

MAXIMUM OPERATING PRESSURE:

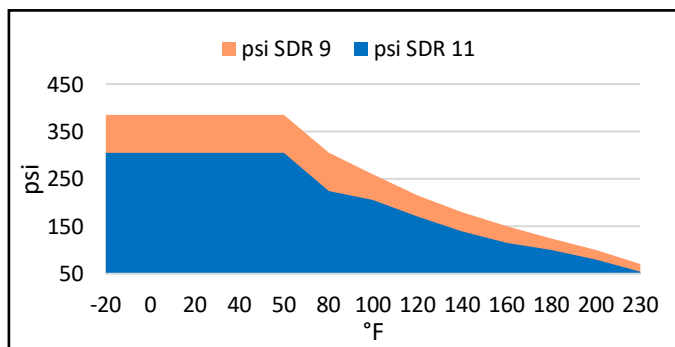

MINIMUM INSULATION THICKNESS PER ASHRAE STANDARD 90.1:

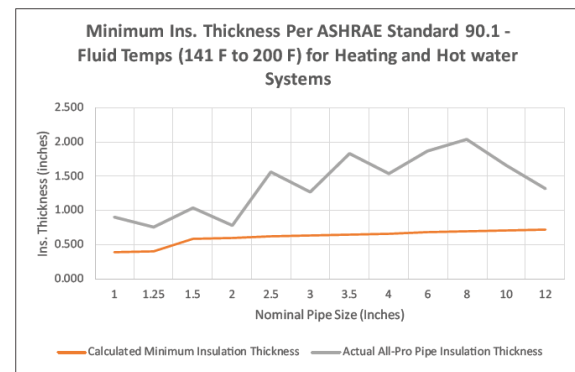

LINEAR EXPANTION RATE:

0.23 in /10°F/100 ft

For code or standard question pertaining to NIRON CLIMA AllPro Pipe and Fittings, contact Nupi Americas.

PRODUCT INFORMATION AND APPLICATION USE:

Niron AllPro preinsulated fittings are manufactured with Niron Clima PP-RCT carrier components that are housed within an IPS Sch. 40 jacket that is extruded with a 30 year U.V. resistant white PP-RCT external layer. The fittings are super insulated with highly efficient closed cell polyurethane foam (PUF) insulation which exceeds the required thickness for the ASHRAE 90.1 Energy Code in all sizes. This style of fitting has carrier pipes extended to allow joining by the AllPro EF or BF method. Each fitting is available in an optional "extended version" which has the centerline-to-end dimension of the fittings extended to allow for clamping in butt fusion machines which have a wide clamp set-up.



Nupi Americas, Inc.
314 Commerce Parkway
Early Branch, SC 29916
Phone: 813-398-3579
Fax: 813-398-3639
Mail: info@nupiamericas.com
Website: www.nupiamericas.com

SUBMITTAL DATA SHEET

NI_AP_IN_0034.docx
Rev. -0 of 09/06/2022

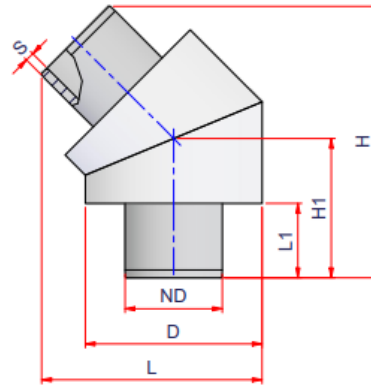

CODE	Weight lbs/pc	Volume ft ³ /pc	ND	D	S	L1	L	H1	H
27NC45AP329MML	2.668	1.0055	1" => 32 mm	4.5	0.14	2	10.15	11.25	19.65
27NC45AP4011MML	2.745	1.0168	1 1/4" => 40 mm	4.5	0.14	2	10.26	11.25	19.76
27NC45AP5011MML	4.569	1.2639	1 1/2" => 50 mm	4.5	0.18	2,5	11.78	12.5	22.03
27NC45AP6311MML	4.775	1.2788	2" => 63 mm	4.5	0.23	2,5	11.97	12.5	22.16
27NC45AP7511MML	13.904	3.0836	2 1/2" => 75 mm	6.63	0.27	3	15.67	16	28.36
27NC45AP9011MML	14.138	3.1294	3" => 90 mm	6.63	0.32	3	15.88	16	28.57
27NC45AP11011MML	23.836	5.1945	3 1/2" => 110 mm	8.63	0.39	4	18.57	18	32.26
27NC45AP12511MML	24.195	5.2624	4" => 125 mm	8.63	0.45	4	18.78	18	32.47
27NC45AP16011MML	35.635	8.2291	6" => 160 mm	10.75	0.58	4	21.75	20	36.37
27NC45AP20011MML	54.189	12.0071	8" => 200 mm	12.75	0.72	4.5	21.72	22	40.34
27NC45AP25011MML	66.387	13.6392	10" => 250 mm	14	0.89	5	26.04	22	41.03
27NC45AP31511MML	98.741	19.0512	12" => 315 mm	16	1.13	6	29.36	24	45.36

MANUFACTURER'S WARRANTY:

Thirty (30) Years from the date of sale upon successful completion of pressure test of the piping system (refer to published warranty for complete details).

NOTE:

* More information can be found on AllPro NIRON TECHNICAL CATALOGUE

*** In order for Niron pipe and fittings to meet E-84 and/or CAN/ULC S102.2 for installation in a plenum application, it must be covered with a minimum of 1" or greater E-84 fiberglass insulation

**** Technical Data may undergo dimensional changes, check revision at the top



Nupi Americas, Inc.
314 Commerce Parkway
Early Branch, SC 29916
Phone: 813-398-3579
Fax: 813-398-3639
Mail: info@nupiamericas.com
Website: www.nupiamericas.com