



SUBMITTAL DATA SHEET

NI_AP_IN_0014.docx
Rev. -0 of 25/05/2022



NIRON CLIMA ALLPRO ELECTROFUSION FITTINGS 45° PREINSULATED ELBOW

ITEM: 27NCEAP_
SIZE RANGE: 1" (32 mm) ÷ 8" (200 mm)
SDR: 11
FUSION RANGE: For Electrofusion – SDR 11 and up
MATERIAL: PP-RCT + Fiber glass + PUF + PPR jacket
COLOR: Grey (carrier pipe) + Grey with white outer layer (jacket pipe)
WELDING SYSTEM:  

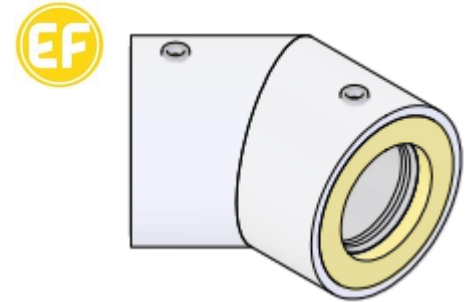

INSTALLATION INSTRUCTIONS:

In accordance with DVS 2207, ASTM D2657 and NUPI AllPro Niron Catalog/Price Sheet

LISTINGS:

uNSF-14; ICC-ES; IAPMO

STANDARDS:

ANS/NSF 14; ASTM F2389; CSA B137.11

MAXIMUM OPERATING PRESSURE:

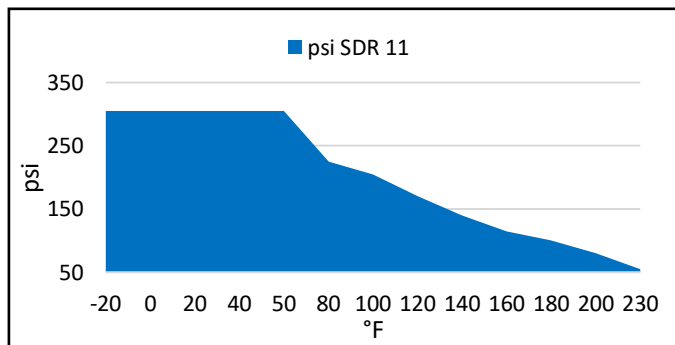

MINIMUM INSULATION THICKNESS PER ASHRAE STANDARD 90.1:

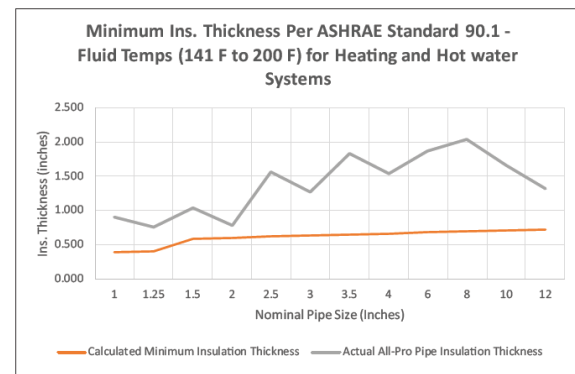

LINEAR EXPANTION RATE:

0.23 in /10°F/100 ft

For code or standard question pertaining to NIRON CLIMA AllPro Pipe and Fittings, contact Nupi Americas.

PRODUCT INFORMATION AND APPLICATION USE:

Niron AllPro preinsulated fittings are manufactured with Niron Clima PP-RCT electrofusion carrier components that are housed within an IPS Sch. 40 jacket that is extruded with a 30 year U.V. resistant white PP-RCT external layer. The fittings are superinsulated with highly efficient closed cell polyurethane foam (PUF) insulation which exceeds the required thickness for the ASHRAE 90.1 Energy Code in all sizes. This style of fitting is extended to allow joining by the AllPro EF method.



Nupi Americas, Inc.
314 Commerce Parkway
Early Branch, SC 29916
Phone: 813-398-3579
Fax: 813-398-3639
Mail: info@nupiamericas.com
Website: www.nupiamericas.com

SUBMITTAL DATA SHEET

NI_AP_IN_0014.docx
Rev. -0 of 25/05/2022

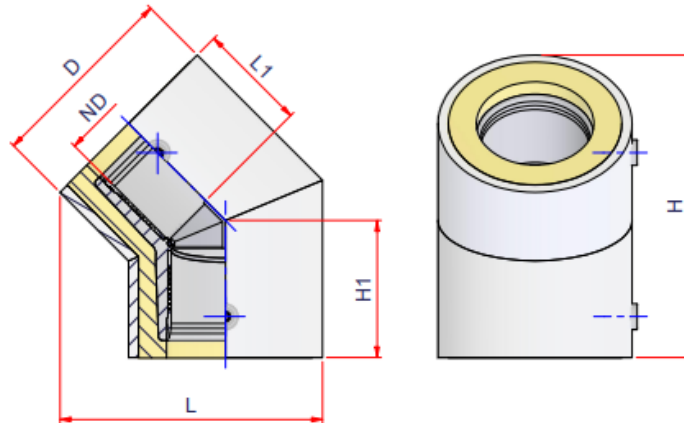

CODE	Weldable SDR	Weight lbs/pc	Volume ft ³ /pc	ND	D	L1	L	H1
27NCEAP32	9	-	0.0505	1" => 32 mm	3.5	2	4.67	2.42
27NCEAP40	11	-	0.0505	1 1/4" => 40 mm	3.5	2	4.67	2.42
27NCEAP50	11	-	0.1005	1 1/2" => 50 mm	4.5	2.5	5.88	2.93
27NCEAP63	11/17	-	0.1003	2" => 63 mm	4.5	2.5	5.88	2.92
27NCEAP75	11/17	-	0.2756	2 1/2" => 75 mm	6.62	3	8.27	3.74
27NCEAP90	11/17	3.717	0.2979	3" => 90 mm	6.62	3	8.47	4.02
27NCEAP110	11/17	6.12	0.6346	3 1/2" => 110 mm	8.62	4	10.91	5.06
27NCEAP125	11/17	8.362	0.6346	4" => 125	8.62	4	10.91	5.06
27NCEAP160	11/17	12.024	1.097	6" => 160 mm	10.75	4	13.14	5.65
27NCEAP200	11/17	22.964	1.9107	8" => 200 mm	12.75	4.5	15.79	6.98

MANUFACTURER' S WARRANTY:

Thirty (30) Years from the date of sale upon successful completion of pressure test of the piping system (refer to published warranty for complete details).

NOTE:

* More information can be found on AllPro NIRON TECHNICAL CATALOGUE

*** In order for Niron pipe and fittings to meet E-84 and/or CAN/ULC S102.2 for installation in a plenum application, it must be covered with a minimum of 1" or greater E-84 fiberglass insulation

**** Technical Data may undergo dimensional changes, check revision at the top



Nupi Americas, Inc.
314 Commerce Parkway
Early Branch, SC 29916
Phone: 813-398-3579
Fax: 813-398-3639
Mail: info@nupiamericas.com
Website: www.nupiamericas.com